Change Summary

CHANGES

No.	Applicable Section(s)	Description	Page(s)
1.	All	Changed from TWINSTAR to OZ9902	All
2.	Ordering Information	Added SN package	1
3.	Functional Description	Added Section 7.0 and Figure 3	9, 12
4.	Package Information	Added SN package information	14

REVISION HISTORY

Revision No.	Revision Summary	Release Date
0.50	Initial Release	2/25/2010

Dual Channel High Power LED Driver

FEATURES

- Dual Channel DC/DC converter
- Constant current or voltage output
- Drives one string of high power LEDs per channel
- 180 degrees phase shift between the two driver outputs
- Independent PWM dimming control for each channel
- Analog dimming
- Constant operation frequency
- Operation frequency synchronization
- Power MOSFET over-current protection
- Over-voltage protection
- Output to return short-circuit protection
- Output to ground short-circuit protection
- Output Over-load protection
- Limited-Current-Condition (LCC) Protection
- Over-Temperature Protection
- FAULT status output

GENERAL DESCRIPTION

OZ9902 is a dual channel high power LED driver designed to build LED backlight for large-size LCD TV applications.

OZ9902 integrates two independently-controlled LED drivers to achieve optimum efficiency. The drive outputs are phase-shifted by 180 degrees to minimize current ripple in high power applications.

The controller supports independent PWM dimming control for each channel and common analog dimming control for both channels. It provides system design flexibility for LCDTV with local dimming or 3D display mode.

OZ9902 can be configured for Master-Slave operation to support multi-channel applications. Synchronization is achieved by a proprietary single-wire interface which minimizes system components.

OZ9902 offers complete protection features such as power MOSFET Over-Current Protection (OCP), Over-Voltage Protection (OVP), output to ground short-circuit protection, output over-load protection, Limited-Current-Condition (LCC) protection, and Over-Temperature Protection (OTP).

ORDERING INFORMATION

Part Number	Temp Range	Package
OZ9902GN	-20°C to 85°C Note 3, Page 3	SOP24 Lead-Free
OZ9902SN	-20°C to 85°C Note 3, Page 3	SSOP24 Lead-Free

SIMPLIFIED APPLICATION

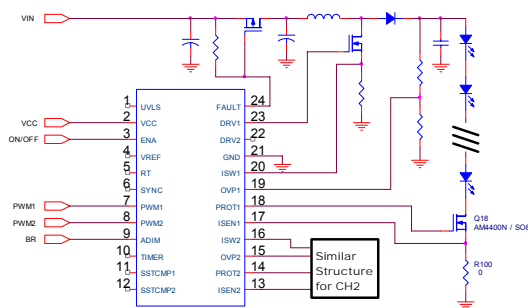

PIN DIAGRAM

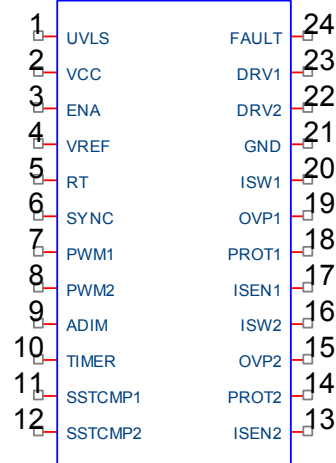

PIN DESCRIPTION

Pin No.	I/O ¹	Name	Description
1	I	UVLS	Power line under-voltage lockout detection.
2	---	VCC	Input power for controller and internal MOSFET driver.
3	I	ENA	ON/OFF control for the controller
4	I/O	VREF	Reference voltage
5	I/O	RT	Resistor to set operation frequency and master/slave mode
6	I/O	SYNC	Operation frequency synchronization signal input/output
7	I	PWM1	PWM dimming control for channel 1
8	I	PWM2	PWM dimming control for channel 2
9	I	ADIM	Analog dimming control for the controller
10	I/O	TIMER	Capacitor setting shutdown delay time
11	I/O	SSTCMP1	Connect resistor and capacitor to set soft start and compensation for channel 1
12	I/O	SSTCMP2	Connect resistor and capacitor to set soft start and compensation for channel 2
13	I	ISEN2	LED current sense input for channel 2
14	O	PROT2	MOSFET driver controlling PWM dimming and short circuit protection for channel 2
15	I	OVP2	Output over-voltage protection sense for channel 2
16	I	ISW2	Power MOSFET switching current sense for channel 2
17	I	ISEN1	LED current sense input for channel 2
18	O	PROT1	MOSFET driver controlling PWM dimming and short circuit protection for channel 1
19	I	OVP1	Output over-voltage protection sense for channel 1
20	I	ISW1	Power MOSFET switching current sense for channel 1
21	---	GND	Ground
22	O	DRV2	Power MOSFET Drive output of channel 2
23	O	DRV1	Power MOSFET Drive output of channel 1
24	O	FAULT	Open-drain status output

Note¹: I=Input, O=Output, I/O=Input/Output

ABSOLUTE MAXIMUM RATINGS²

VCC – Input Voltage	-0.3V---20.0V
DRV1, DRV2, PROT1, PROT2	-0.3V---VCC+0.3V
VREF	-0.3V to 7.0V
SSTCMP1, SSTCMP2, SYNC, RT, TIMER	-0.3V to (VREF + 0.3V)
FAULT	-0.3V to 45.0V
UVLS, ENA, PWM1, PWM2, ADIM, ISW1, ISW2, OVP1, OVP2, ISEN1, ISEN2	-0.3V to 20.0V
Storage Temperature	-55°C to 150°C
Operating Junction Temperature ³	150°C

RECOMMENDED OPERATING RANGE

VCC – Input Voltage	8.0V to 16.0V	
Operating Junction Temperature ³	125°C	
Operating Frequency	100kHz - 1MHz	
PWM Frequency	100Hz – 20kHz	
UVLS, ENA, , PWM1, PWM2, ADIM, ISW1, ISW2, OVP1, OVP2, ISEN1, ISEN2, VREF	0.0V to 5.5V	
DRV1, DRV2, PROT1, PROT2	0.0V to VCC	
SSTCMP1, SSTCMP2 SYNC, RT, TIMER	0.0V to VREF	
FAULT	0.0V to 40.0V	
Operating Ambient Temperature ³	-20°C to 85°C	
Operating Junction Temperature ³	≤125°C	
Thermal Impedance ^{3,4}	θ_{J-C}	θ_{J-A}
24-pin SOP	13°C/W	86 °C/W
24-pin SSOP	36°C/W	96 °C/W

Note²: The “Absolute Maximum Ratings” are those values beyond which the safety of the device cannot be guaranteed and may cause permanent damage to the IC. These are stress ratings only and functional operation of the device at these or any other condition beyond those indicated in the Electrical Characteristics section of the specification is not implied. The “Electrical Characteristics” table defines the conditions for actual device operation. Exposure to absolute maximum rated conditions for extended periods may affect device reliability

Note³: Not to exceed the maximum junction temperature of the IC which relates to the operating power of the IC and the thermal resistance of the IC/package as stated above.

- Using OZ9902 in an application circuit with an ambient temperature near 85°C, the recommended power dissipation of the 24 pin SOP and 24 pin SSOP packages are approximately 234mW and 208mW respectively.
- It is recommended that the customer contact their local O2Micro Field Application Engineer (FAE), if the application is significantly different from the Reference Application Circuit in Figure 2, Page 11.

Note⁴: Still air, low effective thermal conductivity board per JESD51-3.

ELECTRICAL CHARACTERISTICS⁵

All specifications are: $T_a = 25^\circ\text{C}$, $V_{CC} = 12\text{V}$, $R_{RT} = 17.8\text{k}\Omega$ unless otherwise specified.

PARAMETER	SYMBOL	CONDITIONS	LIMITS			UNITS
			MIN	TYP	MAX	
Input Voltage						
VCC Operating Current	VCC			10		mA
VCC Standby Current	VCC			1		uA
VCC Under-Voltage Threshold	$V_{CC_{UVLO}}$	Resume		7.0		V
		Lockout		6.8		V
Controller ON/OFF Control and PWM Logic						
ENA Logic	ENA	Enable	2.0	--		V
		Disable		--	1.0	V
PWM Logic	PWM	Logic High	2.0	--		V
		Logic Low		--	1.0	V
Reference Voltage						
VREF Voltage	VREF	$V_{CC} \geq 7.5\text{V}$		5		V
VREF Sourcing Capability		$V_{CC} \geq 7.5\text{V}$		--	15	mA
VREF Under-Voltage Protection	$V_{REF_{UVLO}}$	Resume		3.8		V
		Lockout		3.6		V
Oscillator and Frequency Synchronization						
Operation frequency		$R_{RT} = 17.8\text{k}\Omega$		365		KHz
SYNC logic	SYNC	Logic high	2	---	--	V
		Logic low	--	--	1	V
LED Current Regulation						
ISEN1/2 reference Voltage	$V_{ISEN1/2}$	$ADIM \geq 1.5\text{V}$		300		mV
		$ADIM \leq 0.5\text{V}$		100		mV

ELECTRICAL CHARACTERISTICS⁵ (Continued)

All specifications are: $T_a = 25^\circ\text{C}$, $V_{CC}=12\text{V}$, $R_{RT}=17.8\text{k}\Omega$ unless otherwise specified.

PARAMETER	SYMBOL	CONDITIONS	LIMITS			UNITS
			MIN	TYP	MAX	
Protection Thresholds						
Line Voltage Under-Voltage Protection	V_{UVLS}			3		V
Output Over-Voltage Protection	V_{OVP}			3		V
Output – Ground Short-Circuit Protection	V_{OVP}			200		mV
Switch Over-Current Protection	$V_{ISW1/2}$			500		mV
Output – Return Short-Circuit Protection	$V_{ISEN1/2}$	ADIM > 1.5V		450		mV
Output Over-Load Protection	$V_{ISEN1/2}$	ADIM > 1.5V		225		mV
Shutdown Delay Timer						
Timer Charge Current	I_{TIMER}			3		μA
Shutdown Threshold	V_{TIMER}			3		V
MOSFET Driver and PROT						
DRV1/2 source resistance	$R_{DSON, SOURCE}$			10		Ω
DRV1/2 sink resistance	$R_{DSON, SINK}$			5		Ω
DRV1/2 minimum on time	$T_{ON, MIN}$			60		ns
DRV1/2 minimum off time	$T_{OFF, MIN}$			200		ns
PROT1/2 source resistance	$R_{DSON, SINK}$			100		Ω
PROT1/2 sink resistance	$R_{DSON, SOURCE}$			50		Ω

FUNCTIONAL BLOCK DIAGRAM

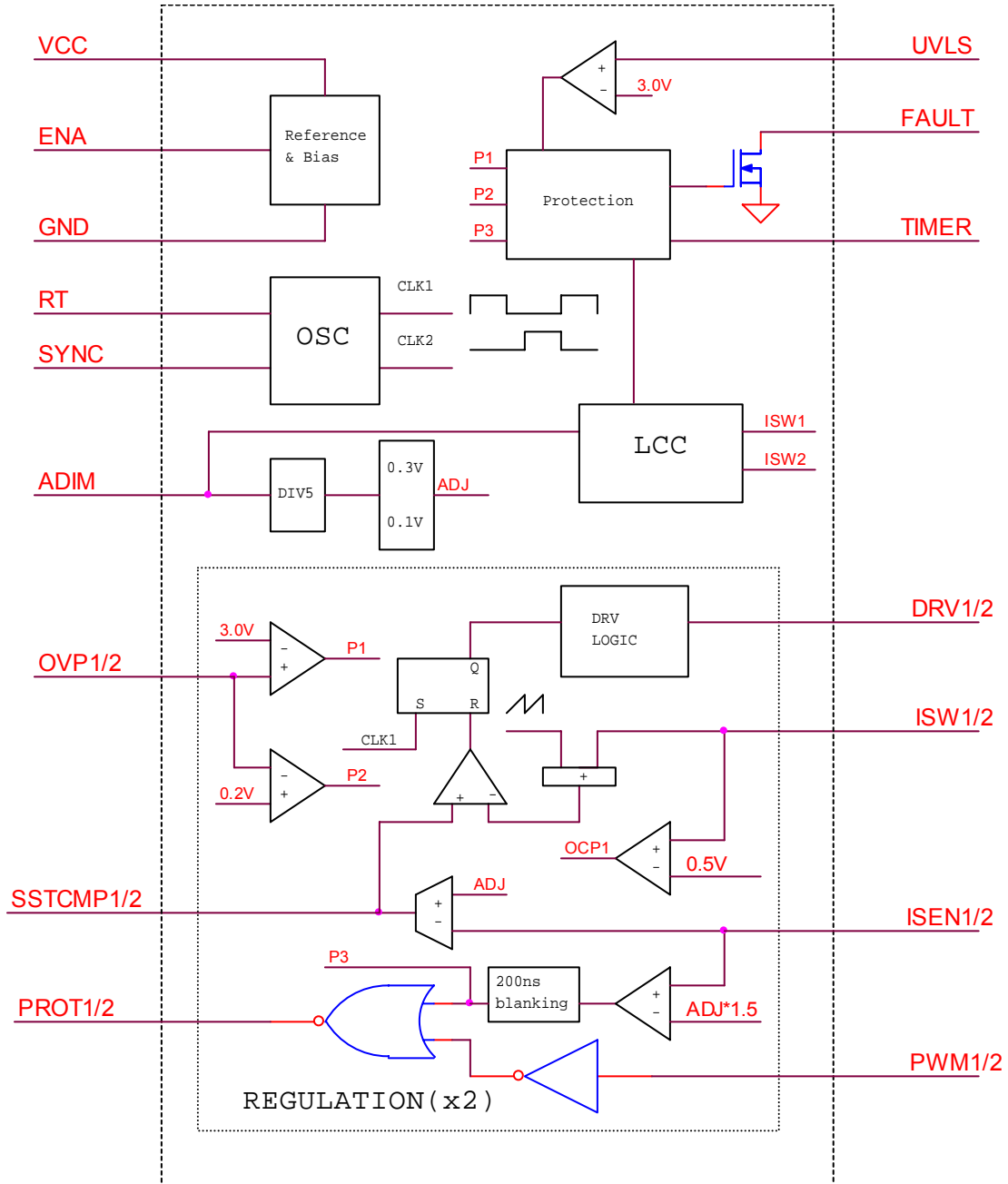

Figure 1

FUNCTIONAL DESCRIPTION

Refer to the Functional Block Diagram in Figure 1, Page 6.

The Reference and Bias block provides the reference voltage, bias current and low voltage supply to the other internal blocks.

The OSC block generates a constant frequency for OZ9902 operation and operation frequency synchronization.

The Regulation block illustrates one of the two regulation channels in OZ9902. Each channel contains an operational trans-conductance amplifier for LED current regulation, a high voltage MOSFET driver, PWM dimming control circuitry and other circuits for various protection features dedicated to its respective channel. The Regulation block is replicated twice in the controller to realize the dual-channel high-power LED driver.

The LCC block monitors the difference between the switching current sensed by pins ISW1/2.

The Protection block contains the FAULT status output and Delay Timer.

Refer to the Typical Application Circuit in Figure 2, Page 11 for the following discussion.

1.0. Enable

OZ9902 is enabled by applying a voltage of greater than approximately 2.0V to pin ENA. Once the controller is enabled, the voltage at VREF rises from 0.0V to 5.0V. A voltage of less than approximately 1.0V at pin ENA disables the controller.

VREF has a typical 10mA source capability at VIN = 12V. If the load current exceeds the VREF source capability, the over-current protection function is triggered and the output current is limited.

When the voltage at pin VREF exceeds a threshold of approximately 3.8V (resume threshold) and the voltage at pin UVLS exceeds a threshold of approximately 3.0V (resume threshold), the IC starts normal operation.

When the voltage at pin VREF drops below a threshold of approximately 3.6V (lockout threshold) or the voltage at pin UVLS drops below a threshold of approximately 2.9V (lockout threshold), the IC stops operation and enters the lockout mode.

An under-voltage lockout protection feature is provided for pin VCC. If the voltage at pin VCC drops below a threshold of approximately 6.8V, the IC will lockout. The IC resumes operation when the voltage at pin VCC exceeds a threshold of approximately 7.0V.

2.0. High Frequency Oscillator

The controller operates in a fixed frequency mode. The constant operating frequency is user-defined by external resistor R_{RT} connected between pin RT and ground.

The operation frequency can be approximated by the following equation:

$$f_{OP} [KHz] = \frac{6497}{R_{RT} [K\Omega]}$$

3.0. Multi-Controller Synchronization

OZ9902 supports a multiple controller application requiring more than two LED strings, with the operating frequency synchronized in Master-Slave mode.

To set the controller to Master mode, connect resistor R_{RT} between pin RT and GND. In Master mode, the pin SYNC is an open-drain output with an operating frequency of two times the frequency of DRV1 or DRV2. Since pin SYNC is open drain, a 2kΩ to 10kΩ pull-up resistor is needed between pin SYNC and pin VREF to have a pulse signal output.

To configure the controller to Slave mode, connect resistor R_{RT} between pins RT and VREF. The resistor value should be same value of that connected to the Master IC. In Slave mode, the pin SYNC is an input pin and receives the synchronizing signal from the Master controller IC.

4.0. LED Current Regulation and Analog Dimming Control

Analog dimming is achieved by applying a voltage in the range of approximately 0.5V to 1.5V to pin ADIM. The LED current is sensed by current sense resistors (R20, R31) connected to pins ISEN1 and ISEN2 respectively. The current regulation at pins ISEN1/2 is in the range of approximately 0.1V to 0.3V. The LED current regulation can be approximated by the following equation

$$I_{LED} [mA] = \frac{V_{ADIM} [mV]}{5 \times R_{ISEN1/2} [\Omega]}$$

If the voltage applied to pin ADIM is greater than approximately 1.5V, the regulated reference voltage at pins ISEN1/2 is fixed at approximately 0.3V. The LED current is approximated by the following equation:

$$I_{LED} [mA] = \frac{300}{R_{ISEN1/2} [\Omega]}$$

If the voltage applied to pin ADIM is less than approximately 0.5V, the regulated reference voltage at pins ISEN1/2 is fixed at approximately 0.1V. The LED current is approximated by the following equation:

$$I_{LED} [mA] = \frac{100}{R_{ISEN1/2} [\Omega]}$$

5.0. PWM Dimming Control

External PWM dimming control is achieved by applying an external PWM signal in the range of 100Hz to 20kHz with a peak of greater than approximately 2.0V and a valley of less than approximately 1.0V to pins PWM1 or PWM2. When the voltage at pins PWM1 or PWM2 exceeds a threshold of approximately 2.0V, the corresponding LED string is turned on. When the voltage at pins PWM1 or PWM2 is less than a threshold of approximately 1.0V, the corresponding LED string is turned off.

The PWM dimming function of the two control channels are independent. Each channel can have different PWM duty cycle. This provides the user with a flexible LCDTV solution using local dimming and 3D display features.

6.0. Protection Features

6.1. Output Over-Voltage Protection

An output over-voltage condition for each channel is monitored independently by the voltage at pins OVP1 and OVP2. During normal operation, when the voltage at either pin, OVP1 or OVP2, exceeds a threshold of approximately 3.0V, the over-voltage protection function is activated and the drive of the corresponding channel is turned off immediately while

corresponding SSTCMP pin voltage is kept floating to maintain the drive duty cycle. Capacitor C_{TIMER} (C9) connected to pin TIMER is charged by an approximate 3uA internal current source.

Once the voltage at the corresponding OVP pin, drops below a threshold of approximately 3.0V before the voltage at the pin TIMER pin exceeds a threshold of approximately 3.0V, the corresponding drive output resumes normal operation and capacitor C_{TIMER} is discharged.

If the over-voltage condition still exists when the voltage at TIMER exceeds a threshold of approximately 3.0V, the corresponding control channel is shut down and latched.

Toggle ENA to restart the IC.

6.2. Output to Ground Short-Circuit Protection

An output to ground short-circuit condition is triggered when the voltage at either pin OVP1 or OVP2 is less than a threshold of approximately 0.2V. The corresponding control channel remains in lockout mode and the status of pin FAULT becomes an open drain.

The condition is removed when the voltage at its respective pin, OVP1 or OVP2, exceeds a threshold of approximately 0.2V and the corresponding control channel resumes normal operation

6.3. Output to Return Short-Circuit Protection

When the LED driver's high voltage output and LED current return path is short-circuited during normal operation, the corresponding LED current switch (Q7 or Q9) is turned off immediately limiting the inrush current and an approximate 3uA current source charges capacitor C_{TIMER} (C9) connected to pin TIMER.

During charging period of capacitor C_{TIMER}, the IC periodically turns on the LED current switch to check whether the short circuit condition still exists. If the short circuit condition is removed before the voltage at pin TIMER reaches a threshold of approximately 3.0V, capacitor C_{TIMER} is discharged and the IC resumes normal operation.

When the voltage at pin TIMER exceeds a threshold of approximately 3.0V and the condition still exists, the corresponding control channel shuts down and latches.

Toggle ENA to restart the IC.

6.4. Power MOSFET Over-Current Protection

The switching current of the power MOSFETs are sensed by their respective resistors connected to pins ISW1 and ISW2. When the voltage at either pin, ISW1 or ISW2, exceeds a threshold of approximately 0.5V, the power MOSFET over-current protection function is triggered. The corresponding power MOSFET is turned off immediately and is not turned on until the next operation cycle.

6.5. Output Over-Load Protection

During normal operation, if the voltage at ISEN1 or ISEN2 drops below ~75% of the normal operation level set by ADIM, the output over-load protection is triggered. An approximate 3uA current source charges capacitor C_{TIMER} connected to pin TIMER.

The corresponding channel shuts down and latches once the voltage at pin TIMER reaches a threshold of approximately 3.0V.

Toggle ENA to restart the IC.

6.6. LCC Protection

To enable the LCC function, connect pin ADIM to pin VREF. This function will stop the LED operation under a serious load imbalance condition, such as, when one of the outputs is shorted to GND with a 2KΩ equivalent resistance.

During normal operation, the IC compares the switching current of the two power MOSFETs (Q7, Q9) through voltages at pins ISW1 and ISW2. If the peak voltage at pins ISW1/2 differs by more than approximately 25%, the LCC protection function is activated. An approximate 3uA current source charges capacitor C_{TIMER} connected to pin TIMER. Once the voltage at pin TIMER reaches a threshold of approximately 3.0V and the condition remains, the IC will shut down and latch.

Toggle ENA to restart the IC.

6.7. Fault Status Indicator

During normal operation, the pin FAULT outputs a logic low condition. When the IC enters the shutdown or lockout mode due to any reason, as

mentioned in sections 6.1- 6.6, pin FAULT becomes an open drain.

Utilizing this function, pin FAULT can control the PMOSFET (Q5) connected between the system power supply and LED driver's power train to cut off the power supply under a fault condition. When this function is implemented, a pre-charge resistor (R6) should be connected across the drain and source of the PMOS transistor to maintain at voltage at pins OVP1/2 at greater than approximately 0.2V to avoid a false output to GND short circuit protection condition.

7.0 Application for Constant Voltage Output

By connecting the corresponding SSTCMP, OVP and ISEN pins together, the two channels of OZ9902 are able to work in parallel. In this mode, OZ9902 can be configured to a dual phase, high power boost DC/DC converter to provide constant output voltage for application needs.

Please refer the reference application in Figure 3, Page 12. The output voltage of the DC/DC converter is set by resistor divider (R58, R36) connected at pins ISEN1/2. The output voltage is approximated by the following equation:

$$V_{out} [V] = V_{ISEN1/2} \times \left(1 + \frac{R58}{R36}\right)$$

8.0 Inductor Selection

OZ9902 can be used in numerous DC/DC converter applications that include boost, buck-boost, SEPIC, flyback etc. In large-size LED backlight application, boost topology is most frequently used; hence the following discussion focuses on the boost converter configuration.

An example is the OZ9902 boost converter operating in both discontinuous and continuous conduction mode. The value of the output inductors, where transition from discontinuous to continuous mode occurs is approximated by the following equation:

$$L_{CRI} = \frac{V_{out} \cdot D \cdot (1 - D)^2 \cdot T}{2 \cdot I_{LED}}$$

The Duty Cycle (D) is calculated by:

$$D = 1 - \frac{V_{in}}{V_{out}}$$

Where,

V_{out} = maximum output voltage

V_{in} = minimum input voltage

T = operating period

I_{LED} = Current in the LED
string

The boost converter operates in discontinuous mode over the entire input voltage range when the inductor value is less than this critical value, L_{CRI} . With an inductance greater than L_{CRI} , the converter operates in continuous mode at the minimum input voltage and may operate in discontinuous mode at higher voltages.

The inductor must be selected with a saturation current rating greater than the peak current provided by the following equation:

$$I_p = \frac{V_{out} \cdot I_{LED}}{0.8 \cdot V_{in}} + \frac{V_{in} \cdot D \cdot T}{2 \cdot L}$$

REFERENCE APPLICATION CIRCUIT FOR CONSTANT CURRENT OUTPUT

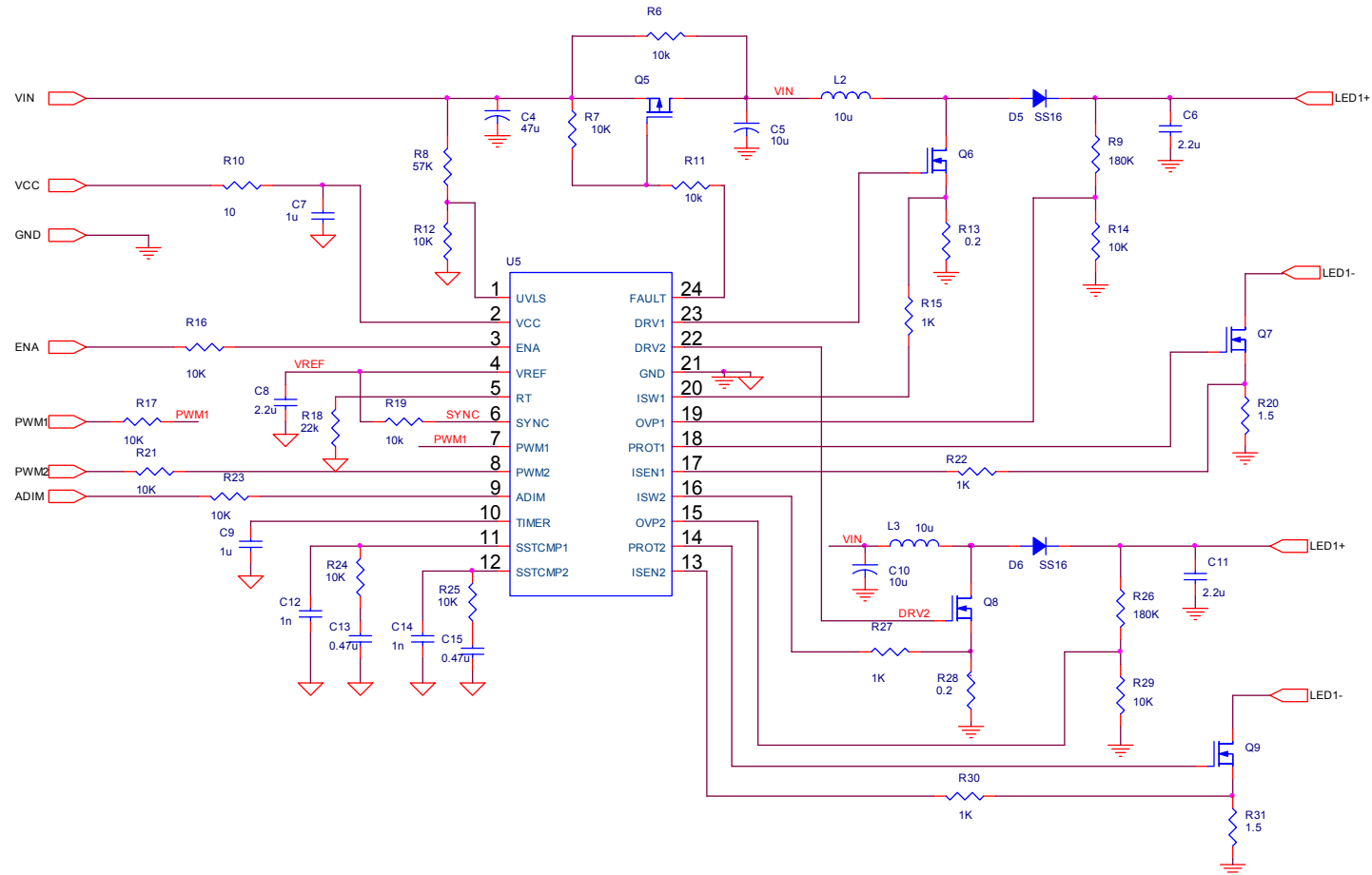

Figure 2

REFERENCE APPLICATION CIRCUIT FOR CONSTANT VOLTAGE OUTPUT

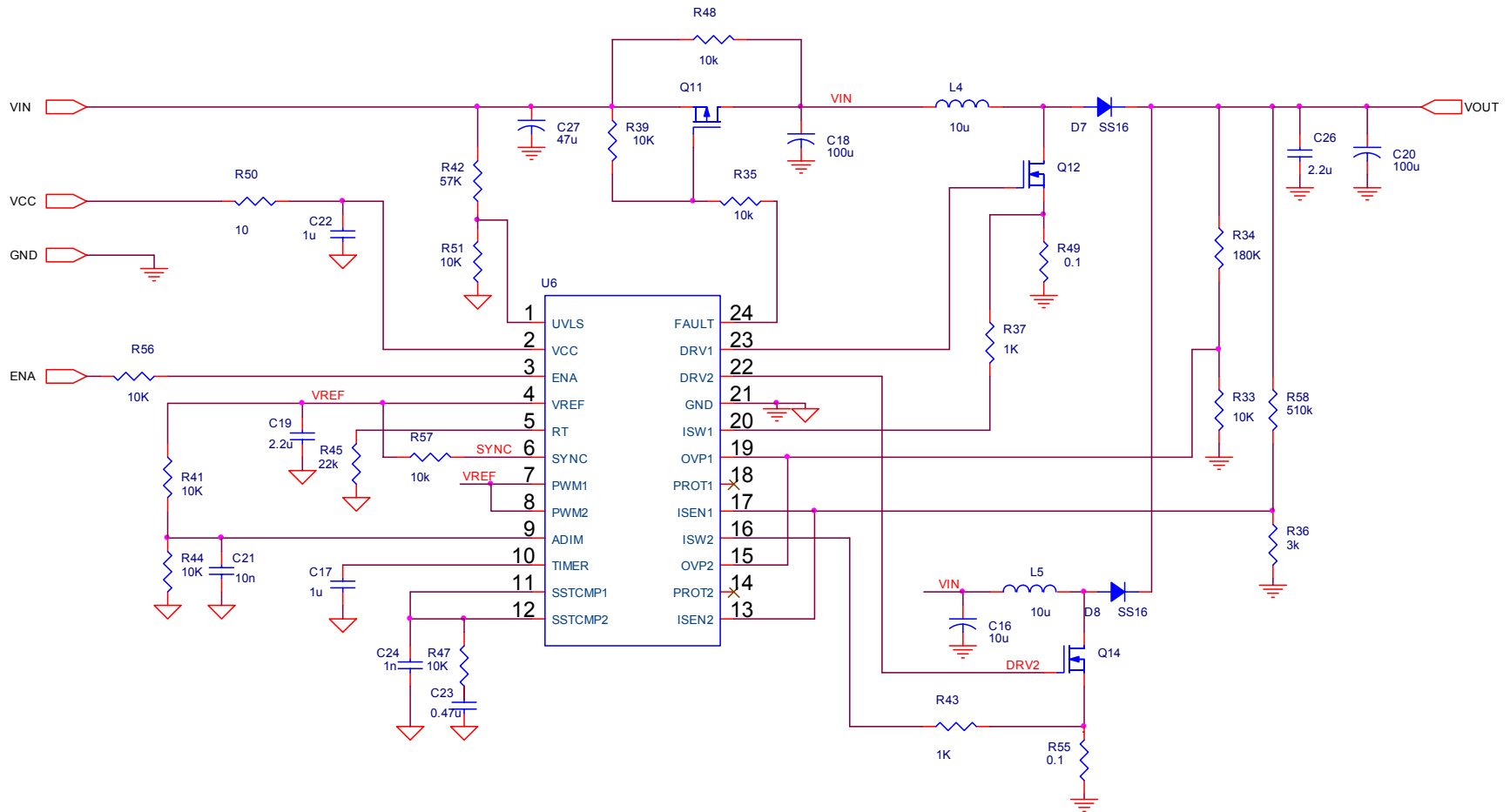
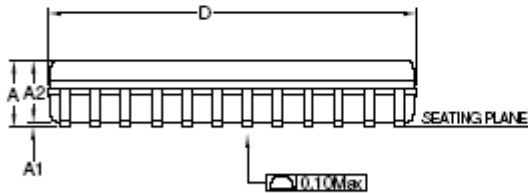
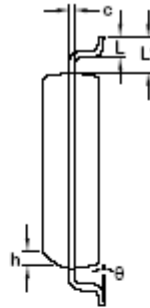
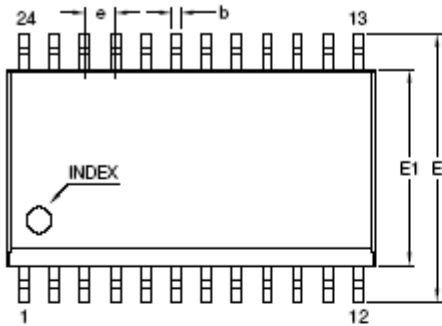

Figure 3

PACKAGE INFORMATION – 24 PIN SOP: OZ9902GN



NOTES:

1. REFER TO JEDEC STD MS-013 AD
2. DIMENSION "D" DOES NOT INCLUDE MOLD FLASH, PROTRUSIONS OR GATE BURRS. MOLD FLASH, PROTRUSIONS OR GATE BURRS SHALL NOT EXCEED 0.15 mm PER END. DIMENSION "E1" DOES NOT INCLUDE INTERLEAD FLASH OR PROTRUSION. INTERLEAD FLASH OR PROTRUSION SHALL NOT EXCEED 0.25 mm PER SIDE

SYMBOL	DIMENSION(MM)		
	MIN	NOM	MAX
A	2,36	2,54	2,64
A1	0,10	0,20	0,30
A2	2,26	-	-
b	0,35	-	0,48
c	0,23	-	0,31
D	15,40 BSC		
E	10,00	10,31	10,65
E1	7,40	7,50	7,60
e	1,27 BSC		
L	0,51	-	1,02
L1	1,40 REF		
h	0,25	-	0,75
θ	0°	-	8°

PACKAGE INFORMATION – 24 PIN SSOP: OZ9902SN

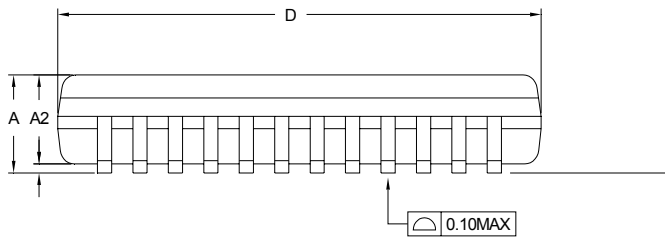
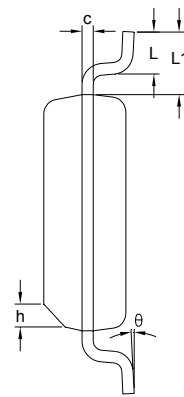
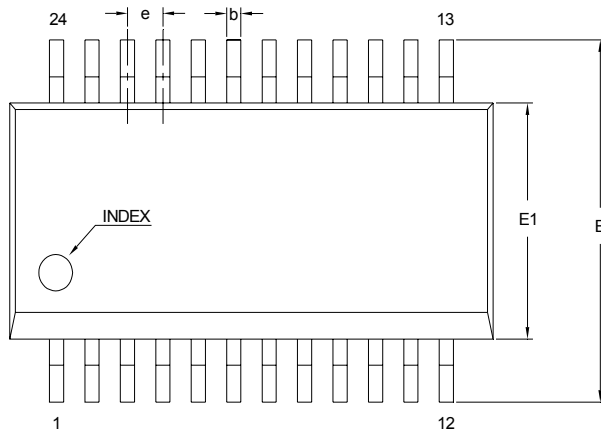

NOTE:

1. REFER TO JEDEC STD MO-137 AE
2. DIMENSION "D" DOES NOT INCLUDE MOLD FLASH, PROTRUSIONS OR GATE BURRS. MOLD FLASH, PROTRUSIONS OR GATE BURRS SHALL NOT EXCEED 0.15 mm PER END. DIMENSION "E1" DOES NOT INCLUDE INTERLEAD FLASH OR PROTRUSION. INTERLEAD FLASH OR PROTRUSION SHALL NOT EXCEED 0.15 mm PER SIDE

SYMBOL	DIMENSION (MM)		
	MIN	NOR	MAX
A	1.35	1.60	1.75
A1	0.10	0.15	0.25
A2	1.25	-	-
b	0.20	-	0.30
c	0.17	-	0.25
D	8.56	8.66	8.76
E	5.80	6.00	6.20
E1	3.80	3.90	4.00
e	0.635 BSC		
L	0.40	-	1.27
L1	1.04 REF		
h	0.25	-	0.50
θ	0°	-	8°

IMPORTANT NOTICE

No portion of O₂Micro specifications/datasheets or any of its subparts may be reproduced in any form, or by any means, without prior written permission from O₂Micro.

O₂Micro and its subsidiaries reserve the right to make changes to their datasheets and/or products or to discontinue any product or service without notice, and advise customers to obtain the latest version of relevant information to verify, before placing orders, that information being relied on is current and complete. All products are sold subject to the terms and conditions of sale supplied at the time of order acknowledgment, including those pertaining to warranty, patent infringement, and limitation of liability.

O₂Micro warrants performance of its products to the specifications applicable at the time of sale in accordance with O₂Micro's standard warranty. Testing and other quality control techniques are utilized to the extent O₂Micro deems necessary to support this warranty. Specific testing of all parameters of each device is not necessarily performed, except those mandated by government requirements.

Customer acknowledges that O₂Micro products are not designed, manufactured or intended for incorporation into any systems or products intended for use in connection with life support or other hazardous activities or environments in which the failure of the O₂Micro products could lead to death, bodily injury, or property or environmental damage ("High Risk Activities"). O₂Micro hereby disclaims all warranties, and O₂Micro will have no liability to Customer or any third party, relating to the use of O₂Micro products in connection with any High Risk Activities.

Any support, assistance, recommendation or information (collectively, "Support") that O₂Micro may provide to you (including, without limitation, regarding the design, development or debugging of your circuit board or other application) is provided "AS IS." O₂Micro does not make, and hereby disclaims, any warranties regarding any such Support, including, without limitation, any warranties of merchantability or fitness for a particular purpose, and any warranty that such Support will be accurate or error free or that your circuit board or other application will be operational or functional. O₂Micro will have no liability to you under any legal theory in connection with your use of or reliance on such Support.

COPYRIGHT © 2007-2010, O₂Micro International Limited